

# FormaTred Scaffold

This billboard standard offers a multitude of applications.

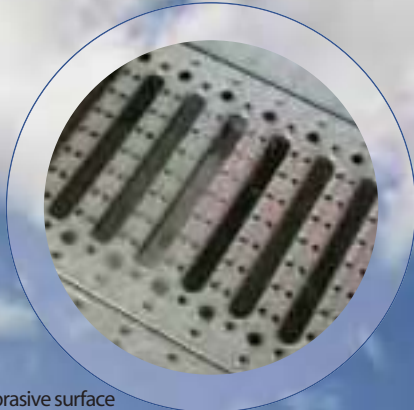

The non-abrasive surface provides superior grip under any conditions.

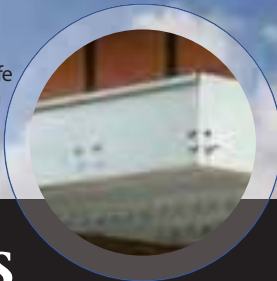

4" Kickrails provide a safe and secure working platform

## Assembly Instructions

# Formetco Forma-Tred Scaffold

- *16 GA Galvanized Steel designed for years of service*
- *Meets or exceeds OSHA Outdoor Industry requirements*
- \* *Kits available for all standard poster and bulletin billboard structures*
- *All direction uniform pattern provides an outstanding surface grip under any weather conditions*
- *Surface designed to be non-abrasive without sacrificing grip*
- *4" Kickrails provide a safe, secure working platform*
- *Hardware for wood pole structures.*

## Table of Contents

|  |         |
|--|---------|
| Forma-Tred Scaffold - - - - -                          | 3 - 4   |
| Forma-Tred Scaffold Assembly - - - - -                 | 5 - 6   |
| Forma-Tred Scaffold Kits Parts List - - - - -          | 7       |
| Scaffold Support Hardware-- - - - -                    | 8       |
| Forma-Tred Scaffold Support Plates- - - - -            | 9       |
| Forma-Tred Scaffold Wood Pole Hardware- - - - -        | 10 - 11 |
| Conduit Support Brackets - - - - -                     | 12      |
| QuickChange™ Ad-View Conduit Support Bracket - - - - - | 13      |
| Forma-Tred Walkaround Scaffold Assembly- - - - -       | 14      |
| Walkaround Handrail Assembly - - - - -                 | 15 - 16 |
| Forma-Tred Scaffold Typical Bolt Spacing-- - - - -     | 17 - 18 |
| Walkaround Scaffold Typical Bolt Spacing - - - - -     | 19      |

# Forma-Tred Scaffold

## 16 gauge Forma-Tred Scaffold

The Forma-Tred 12" Scaffold is designed for poster panels or bulletins, for front and rear scaffolds. Each piece of the 16 gauge Forma-Tred 12" Scaffold is 12" wide x 2 1/2" high and 24' in length. Special lengths available. The legs interlock for added strength.

Forma-Tred 12" Scaffold bolts together using 3/8" x 1" GR5 Bolts/ Flange Nuts allowing you to add sections to meet your required length and to completely recover the scaffold should you need to take down or move the structure. Single lengths can be used within the structure for rotary crews and flexible vinyl crews to stand on while changing out the sections or vinyls. 4" Kickrails are required by OSHA.

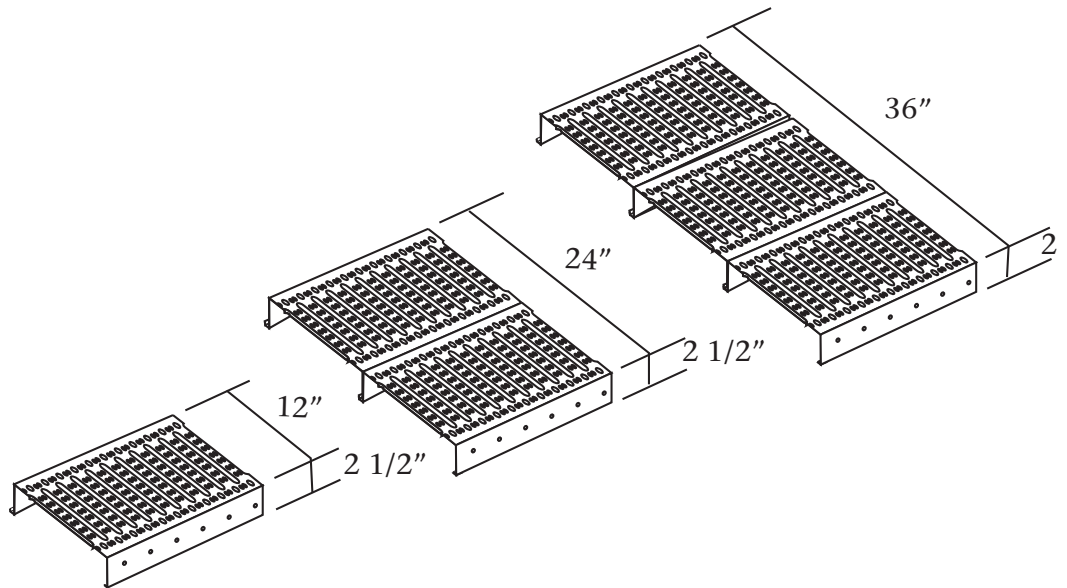

## Scaffold Splice Plates

Use Formetco Scaffold Splice Plates to connect Forma-Tred Scaffold end-to-end.

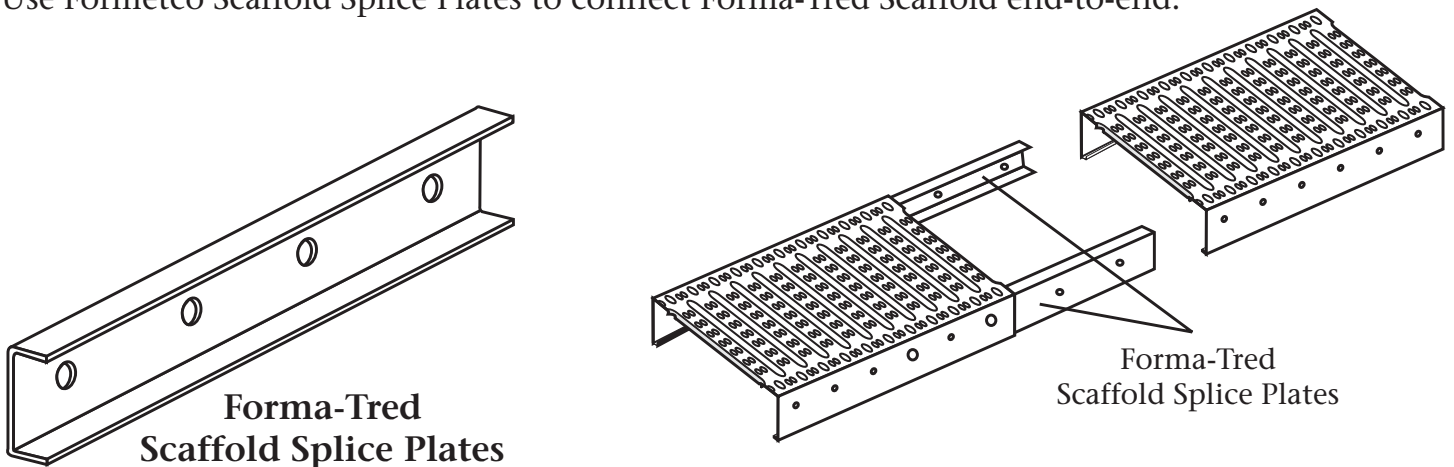

# Forma-Tred Scaffold

The Formetco Forma-Tred Scaffold is designed to meet or exceed the OSHA requirements with 4" Kickrails on all sides. Formetco Forma-Tred Scaffold is available in widths of 20", 24", 30" and 36" and lengths of 24' to 80'. Formetco Forma-Tred Scaffold can be ordered with Walkarounds and Walkarounds with Handrails.

The 16 gauge Formetco Forma-Tred Scaffold has interlocking legs for added strength. The surface is nonskid and designed to prevent wear on the worker's shoes, prevent tears in the worker's clothing or cuts on the worker's hands or knees when they are in a kneeling position working on lights or attaching flexible vinyls.

Scaffold is sold in kits, all the components come automatically according to the size you order. The Hook Bolts and "J" Clips or "VJ" Clips, see Page 8, to secure the Scaffold set to your scaffold supports are not included.

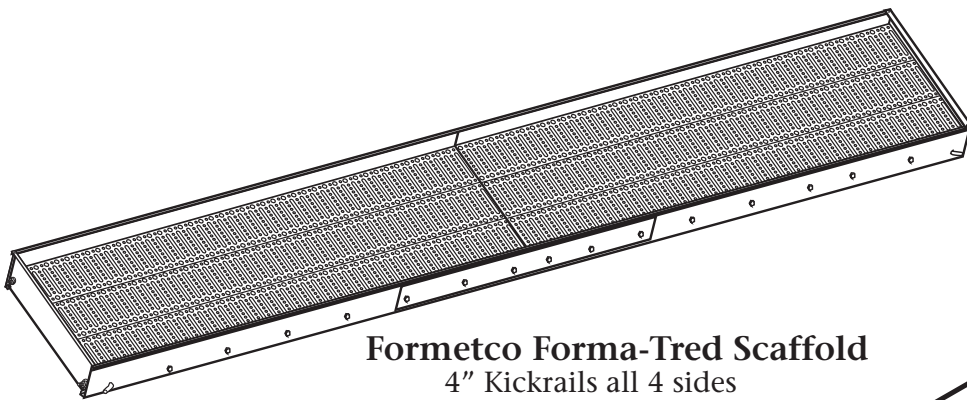

**Formetco Forma-Tred Scaffold**  
4" Kickrails all 4 sides

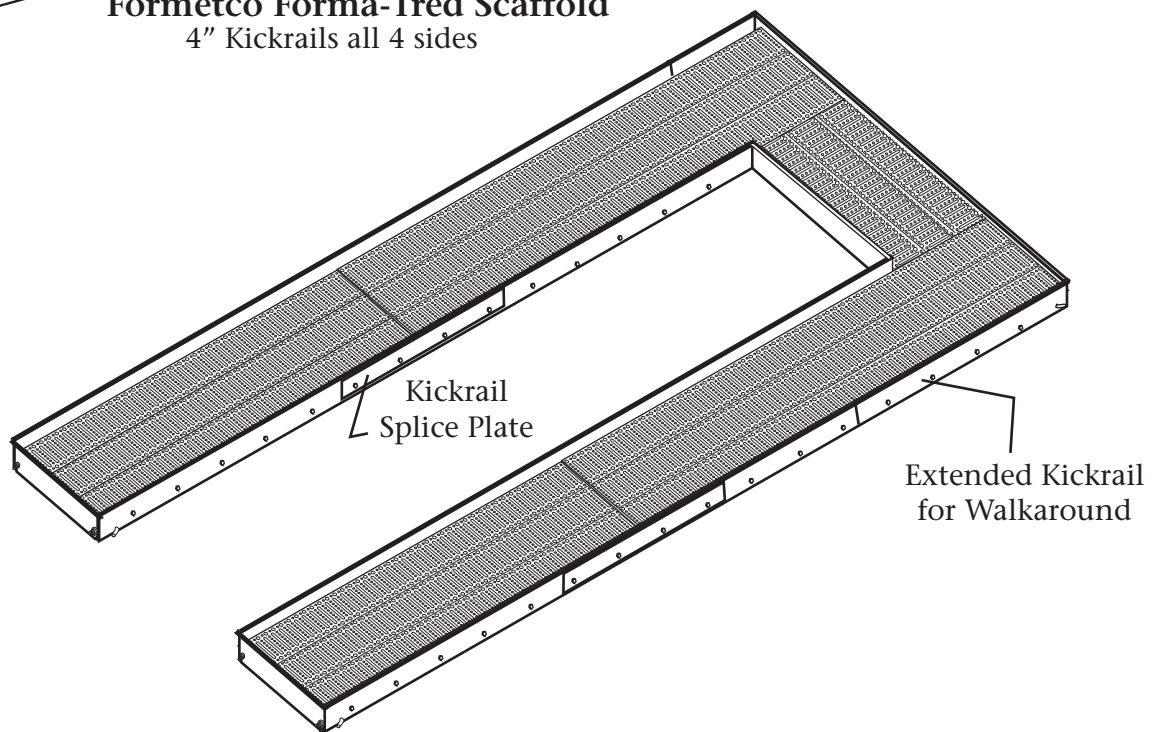

**Formetco Forma-Tred Walkaround Scaffold**  
with 4" Kickrails per OSHA requirements



# Forma-Tred Scaffold

Choose area where you can set up several sawhorses or stands on which you can assemble the Forma-Tred Scaffold. Have two setups when doing Forma-Tred Scaffold over 24' in length so both sides can be assembled and then butted together to connect with Splice Plates. You can wait and butt together on site and then lift in place on the structure.

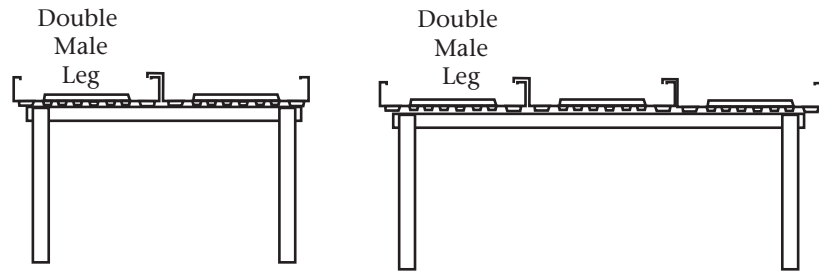
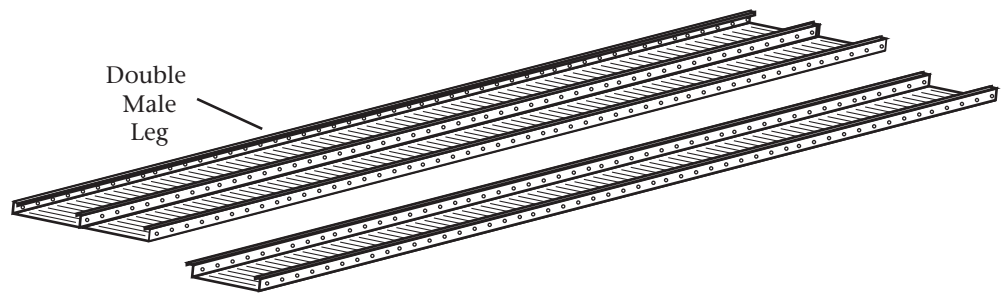

Place a Double Male (D/M) Section of the Forma-Tred Scaffold on stands or sawhorses. Interlock one or two regular, male/female type sections together with the double male section. Make sure that the ends are even, bolt ends together. Only hand tighten the ends at this time.

Start at the center of the Scaffold length, using 3/8"x1" Bolts/Nuts/Washers to secure the interlocked Scaffold sections together every 24". If the Forma-Tred Scaffold is more than 24' in length, assemble the second set in the same method.

When both sets are assembled, butt the two sets end-to-end. Now you are ready to attach the Scaffold Splice Plates. Place one Scaffold Splice Plate on each side of each of the interlocking legs.

Note: Do NOT attach Scaffold Splice Plates to the outside legs at this time.

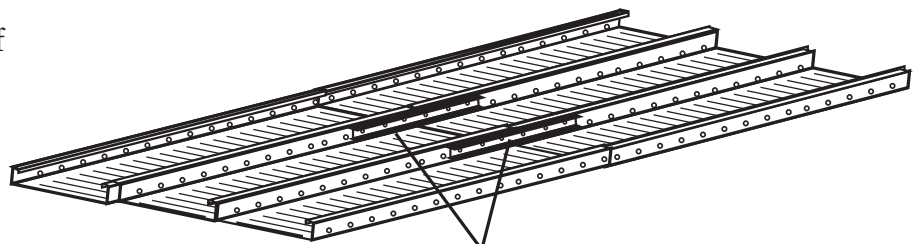

They will be attached along with the Kickrail Splice Plates. Attach the Scaffold Splice Plates with 4 - 3/8"x1" Bolts/Nuts/Washers.

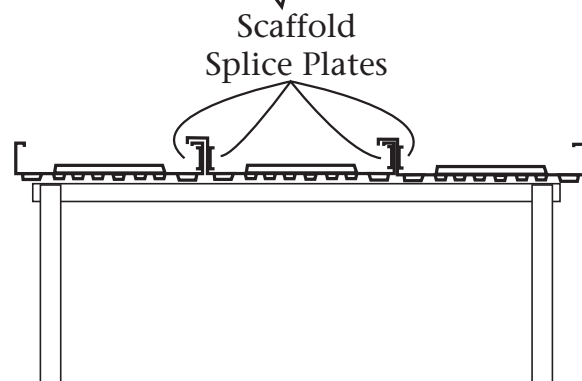

Now you are ready to attach the Kickrails.

# Forma-Tred Scaffold

Secure the Kickrails to each set on both sides with 3/8"x1" Bolts/Nuts/Washers, typically every 36", in the pre-punched holes in the Kickrails. Do not install a bolt/nut/washer at the ends at this time.

Center a Kickrail Splice Plate across the butt joint. Using 3/8"x1" Bolts/Nuts/Washers secure to FS Scaffold with a FS Splice Plate on the inside of the outside legs.

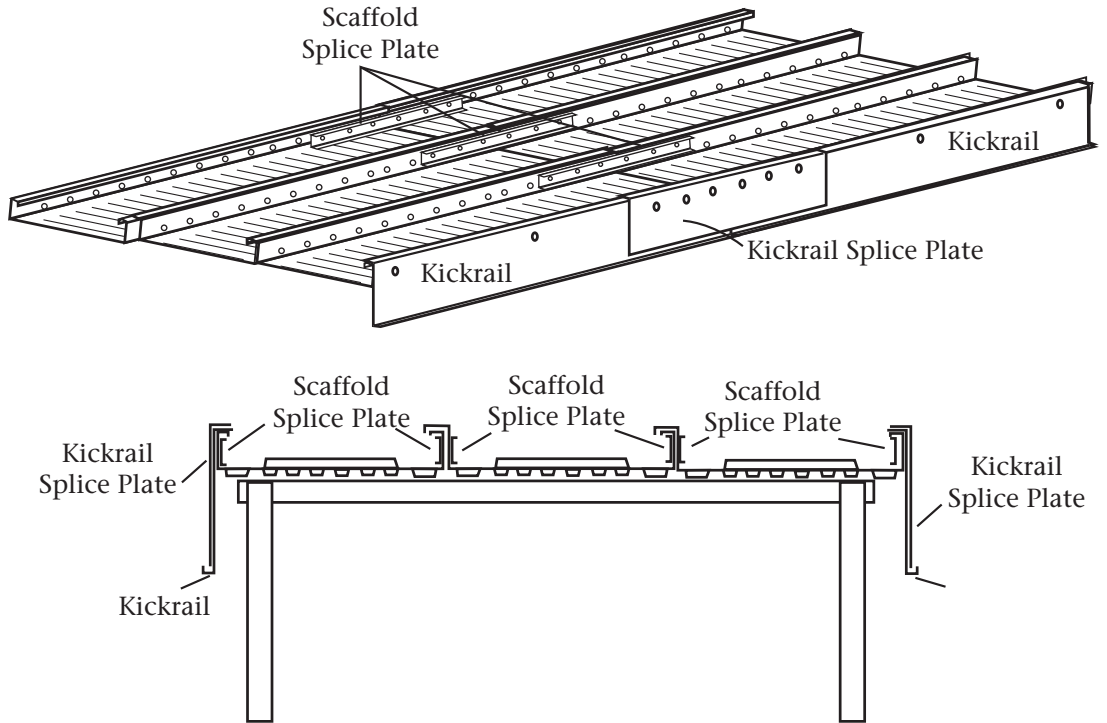

Install the Kickrail End Plates by inserting 2" "V" Bolts through the end holes of the Kickrail on each side at the ends of the FS Scaffold. Place the Kickrail End Plate holes over the "V" Bolt. The Kickrail End Plate fits between the side Kickrails with the top flange overlapping. Attach a washer and nut on each "V" Bolt and tighten. On each side install screws through the top flange of the End Plate through the Kickrail flange securing the End Plate to the Kickrail flanges.

Important: Do NOT leave out any bolt/nut/washer.

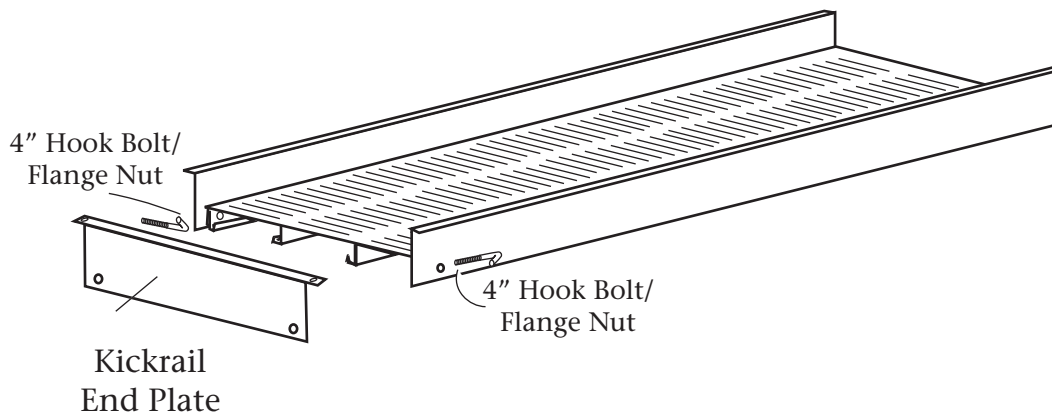

# Forma-Tred Scaffold

## Scaffold Kit Components

The Chart below shows all components that are included in each Scaffold Kit.

| Scaffold Kits<br>24" and 36" widths<br>(Other sizes available) |                           |                           |                           |                           |                           |                           |                           |                           |                           |                           |                           |                           |                           |                           |                           |                           |                           |                           |     |
|--|---------------------------|---------------------------|---------------------------|---------------------------|---------------------------|---------------------------|---------------------------|---------------------------|---------------------------|---------------------------|---------------------------|---------------------------|---------------------------|---------------------------|---------------------------|---------------------------|---------------------------|---------------------------|-----|
|  | *SCAFFKR24X24 (24" x 24') | *SCAFFKR24X30 (24" x 30') | *SCAFFKR24X32 (24" x 32') | *SCAFFKR24X36 (24" x 36') | *SCAFFKR24X40 (24" x 40') | *SCAFFKR24X42 (24" x 42') | *SCAFFKR24X44 (24" x 44') | *SCAFFKR24X48 (24" x 48') | *SCAFFKR24X60 (24" x 60') | *SCAFFKR36X24 (36" x 24') | *SCAFFKR36X30 (36" x 30') | *SCAFFKR36X32 (36" x 32') | *SCAFFKR36X36 (36" x 36') | *SCAFFKR36X40 (36" x 40') | *SCAFFKR36X42 (36" x 42') | *SCAFFKR26X44 (36" x 44') | *SCAFFKR36X48 (36" x 48') | *SCAFFKR36X60 (36" x 60') |     |
| Component Description  | Qty                       | Qty                       | Qty                       | Qty                       | Qty                       | Qty                       | Qty                       | Qty                       | Qty                       | Qty                       | Qty                       | Qty                       | Qty                       | Qty                       | Qty                       | Qty                       | Qty                       | Qty                       | Qty |
| 16 GA 12" D/M Scaffold 12'                                     |                           | 1                         |                           | 1                         |                           |                           |                           |                           | 1                         |                           | 1                         |                           | 1                         |                           |                           |                           |                           |                           | 1   |
| 16 GA 12" Scaffold 12'   |                           | 1                         |                           | 1                         |                           |                           |                           |                           | 1                         |                           | 2                         |                           | 2                         |                           |                           |                           |                           |                           | 2   |
| 16 GA 12" D/M Scaffold 16'                                     |                           |                           | 2                         |                           | 1*                        |                           |                           |                           |                           |                           |                           | 2                         |                           | 1*                        |                           |                           |                           |                           |     |
| 16 GA 12" Scaffold 16'   |                           |                           | 2                         |                           | 1*                        |                           |                           |                           |                           |                           |                           | 4                         |                           | 2*                        |                           |                           |                           |                           |     |
| 16 GA 12" D/M Scaffold 18'                                     |                           | 1                         |                           |                           |                           | 1                         |                           |                           |                           |                           | 1                         |                           |                           |                           | 1                         |                           |                           |                           |     |
| 16 GA 12" Scaffold 18'   |                           | 1                         |                           |                           |                           | 1                         |                           |                           |                           |                           | 2                         |                           |                           |                           | 2                         |                           |                           |                           |     |
| 16 GA 12" D/M Scaffold 20'                                     |                           |                           |                           |                           | 2                         |                           | 1                         |                           |                           |                           |                           |                           |                           | 2                         |                           | 1                         |                           |                           |     |
| 16 GA 12" Scaffold 20'   |                           |                           |                           |                           | 2                         |                           | 1                         |                           |                           |                           |                           |                           |                           | 4                         |                           | 2                         |                           |                           |     |
| 16 GA 12" D/M Scaffold 24'                                     | 1                         |                           |                           | 1                         | 1*                        | 1                         | 1                         | 2                         | 2                         | 1                         |                           |                           | 1                         | 1*                        | 1                         | 1                         | 2                         | 2                         |     |
| 16 GA 12" Scaffold 24'   | 1                         |                           |                           | 1                         | 1*                        | 1                         | 1                         | 2                         | 2                         | 2                         |                           |                           | 2                         | 2*                        | 2                         | 2                         | 4                         | 4                         |     |
| 2 1/2" Scaffold Splice Plates                                  |                           | 4                         | 4                         | 4                         | 4                         | 4                         | 4                         | 4                         | 8                         |                           | 6                         | 6                         | 6                         | 6                         | 6                         | 6                         | 6                         | 6                         | 12  |
| 14 GA Kickrail 12'   |                           | 2                         |                           | 2                         |                           |                           |                           |                           | 2                         |                           | 2                         |                           | 2                         |                           |                           |                           |                           |                           | 2   |
| 14 GA Kickrail 16'   |                           |                           | 4                         |                           |                           |                           |                           |                           |                           |                           |                           | 4                         |                           |                           |                           |                           |                           |                           |     |
| 14 GA Kickrail 18'   |                           |                           | 4                         |                           |                           |                           |                           |                           |                           |                           |                           | 4                         |                           |                           |                           |                           |                           |                           |     |
| 14 GA Kickrail 20'   |                           |                           |                           | 4                         |                           | 2                         |                           |                           |                           |                           |                           |                           | 4                         |                           | 2                         |                           |                           |                           |     |
| 14 GA Kickrail 24'   | 2                         |                           |                           | 2                         |                           | 2                         | 2                         | 4                         | 4                         | 2                         |                           |                           | 2                         |                           | 2                         | 2                         | 4                         | 4                         |     |
| 14 GA End Kickrail 20"   |                           |                           |                           |                           |                           |                           |                           |                           |                           |                           |                           |                           |                           |                           |                           |                           |                           |                           |     |
| 14 GA End Kickrail 24"   | 2                         | 2                         | 2                         | 2                         | 2                         | 2                         | 2                         | 2                         | 2                         | 2                         |                           |                           |                           |                           |                           |                           |                           |                           |     |
| 14 GA End Kickrail 30"   |                           |                           |                           |                           |                           |                           |                           |                           |                           |                           |                           |                           |                           |                           |                           |                           |                           |                           |     |
| 14 GA End Kickrail 36"   |                           |                           |                           |                           |                           |                           |                           |                           |                           |                           | 2                         | 2                         | 2                         | 2                         | 2                         | 2                         | 2                         | 2                         | 2   |
| Kickrail Splice Plate 52"                                      |                           | 2                         | 2                         | 2                         | 2                         | 2                         | 2                         | 2                         | 4                         |                           | 2                         | 2                         | 2                         | 2                         | 2                         | 2                         | 2                         | 2                         | 4   |
| 3/8" DIA x 1" GR5 Bolt/FI Nut                                  |                           |                           |                           |                           |                           |                           |                           |                           |                           |                           |                           |                           |                           |                           |                           |                           |                           |                           |     |
| 2" x 3/8" DIA Hook Bolt/FI Nut                                 | 4                         | 4                         | 4                         | 4                         | 4                         | 4                         | 4                         | 4                         | 4                         | 4                         | 4                         | 4                         | 4                         | 4                         | 4                         | 4                         | 4                         | 4                         | 4   |

\* Optional Package depending on inventory.



Excellence is our standard.

# Forma-Tred Scaffold

## Scaffold Support Hardware

Below is a chart showing hardware needed to attach Forma-Tred Scaffold to 4" Channel and Angle Iron Supports.

Forma-Tred Scaffold w/Kickrail  
with C4 x 5.4 Channel Supports

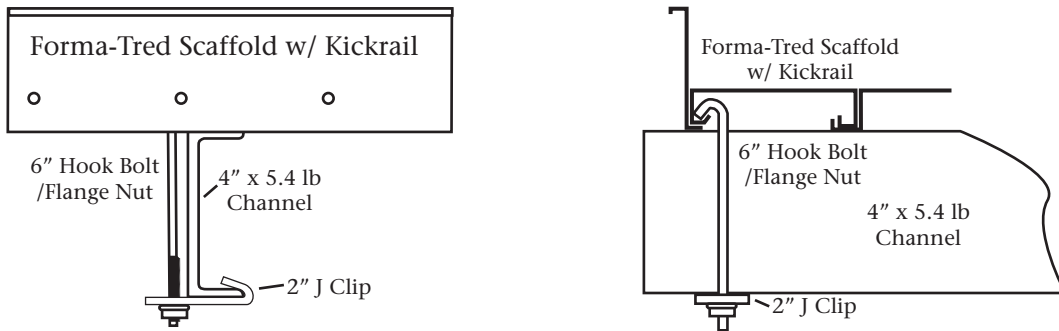

Formetred Scaffold  
Back Scaffold no Kickrails

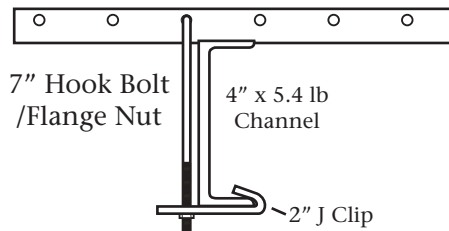

Forma-Tred Scaffold w/Kickrail  
with Angel Iron Supports

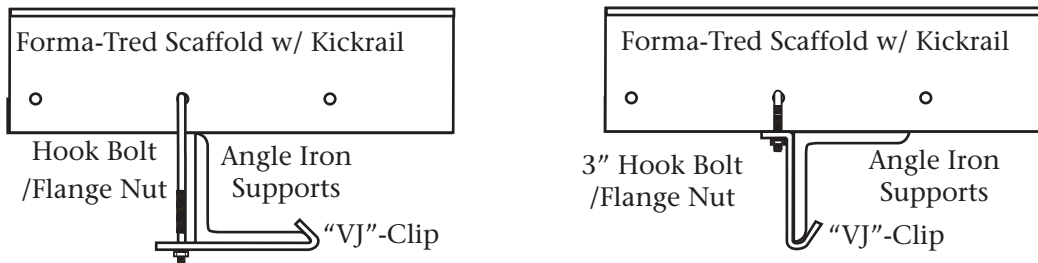

How to Order

| Angle Length | "J"-Clip Length | Hook Bolt Length |
|--------------|-----------------|------------------|
| 2 1/2"       | 2 1/2"          | 5"               |
| 3"           | 3"              | 5"               |
| 3 1/2"       | 3 1/2"          | 6"               |
| 4"           | 4"              | 6"               |

How to Order

| Angle Length | "VJ"-Clip Length | Hook Bolt Length |
|--------------|------------------|------------------|
| 2 1/2"       | 2 1/2"           | 3"               |
| 3"           | 3"               | 3"               |
| 3 1/2"       | 3 1/2"           | 3"               |
| 4"           | 4"               | 3"               |



Excellence is our standard.

# Forma-Tred Scaffold Support Plates

## Scaffold Support Plate

Formetco Scaffold Support Plate, made of 1/4" steel plate, can be welded or bolted to each side of the I-beam upright. A 4" - 5.4 lb Channel Iron is inserted through the slots for supporting Forma-Tred Scaffold. The 4" - 5.4 lb Channel Iron can be used to support the Forma-Tred Scaffold on one side or for a back to back structure.

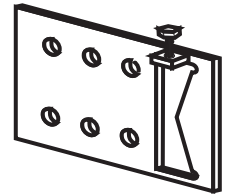

## Scaffold Support Plate

When the channel iron is in position, tighten the attached bolts on the Support Channel to secure the channel iron in place.

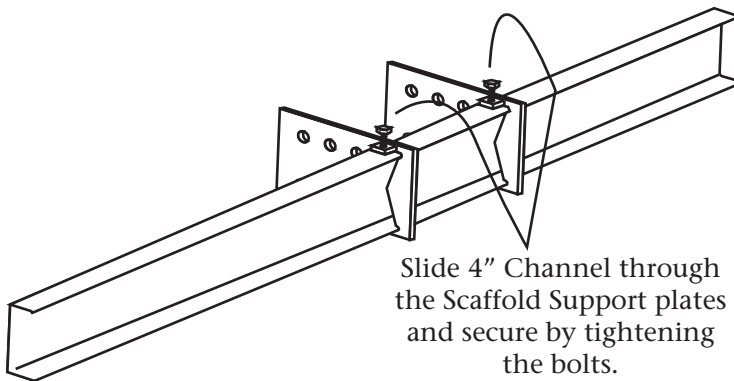

Slide 4" Channel through the Scaffold Support plates and secure by tightening the bolts.

Place the Forma-Tred Scaffolds on the channel irons and using 2" "J" Clips and the proper Hook Bolt/Nut secure the Forma-Tred Scaffold to the channel iron.

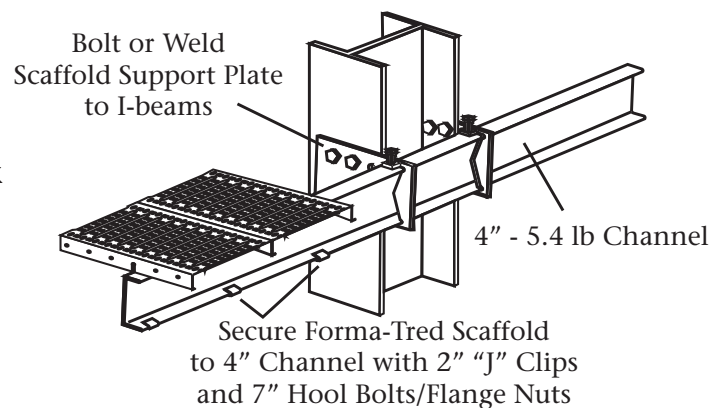

## Scaffold Support "C" Bracket

The Scaffold Support "C" Bracket can be welded or bolted to the uprights. Slide a 4" - 5.4 lb. Channel through the slots to support Forma-Tred Scaffolds. It can be used for single face, rear walks or back-to-back scaffolds. Secure the channel iron by tightening one top bolt, then the opposite bottom bolt, top bolt above and then last bottom bolt.

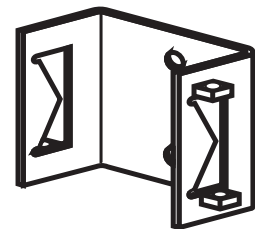

## Scaffold Support "C" Bracket

# Forma-Tred Scaffold Support Assembly

## Scaffold Support Assembly

Formetco Scaffold Support Assembly is a "C" Support Bracket welded to a 30" - 4" 5.2 lb Channel Iron. The Scaffold Support Assembly includes the "C" Assembly, one (1) 3/4"x36" Threaded Rods with four (4) nuts/washers, two (2) 4" - 5.4 lb. x 4" Back Channel Washers, all Bolts/Nuts/Washers needed and with or without the 4" 5.4 lb Channel Scaffold Supports.

## Mounting Scaffold Support Assembly

Using a string level, locate on each wood pole the top of the "C" Assembly. Place the "C" Assembly on each pole and mark the hole locations for threaded rods. Drill two 13/16" holes in each pole for the "C" Assembly threaded rods. Insert threaded rods through the holes and "C" Assembly. Place a washer and nut on the rods. Place a 4" x 4" Channel Back on the opposite side of the pole along with nut/washer and tighten. Insert 4" 5.4 lb Channels through slots and secure.

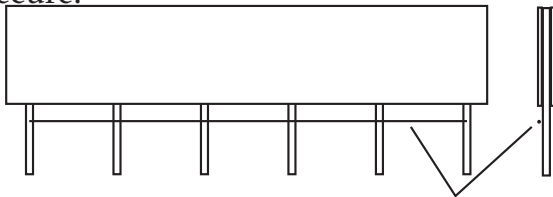

Run a string level or laser where you want the Scaffold. Place a nail in each wood pole and run a string from one end to the other.

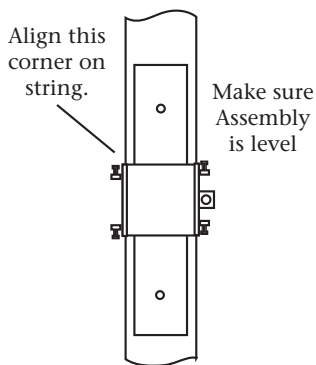
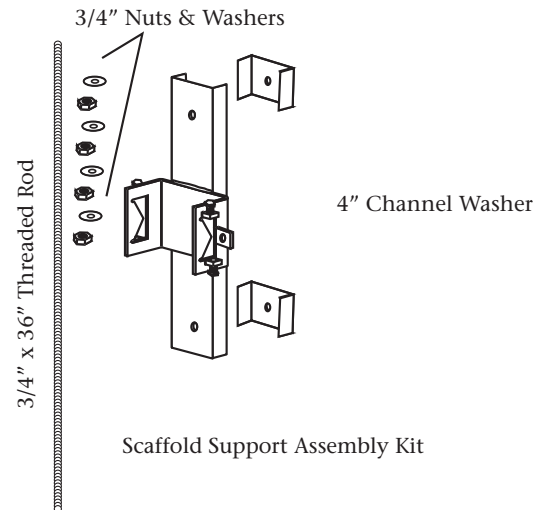

Place Scaffold Assembly on wood pole and drill pilot holes for threaded rods.

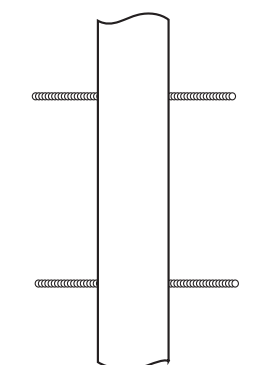

Drill two 13/16" holes through the wood pole. Cut 2 -3/4" threaded rods 5" longer than the pole is across and drive through the holes

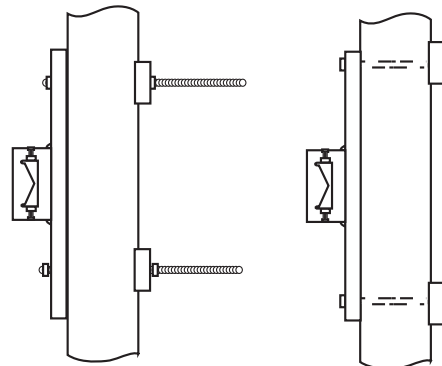

Place the Scaffold Assembly on the threaded rods. Place a washer and nut on each rod. Tighten nut until end of rod is flush with nut. Place a 4" Channel Washer on threaded rods. Tighten nuts. Cut off excess rods.

# Forma-Tred Scaffold Support Assembly

## Front Scaffold Assembly Wood pole structure

### Single Face Scaffold Support Assembly Kit for Wood Pole Structure.

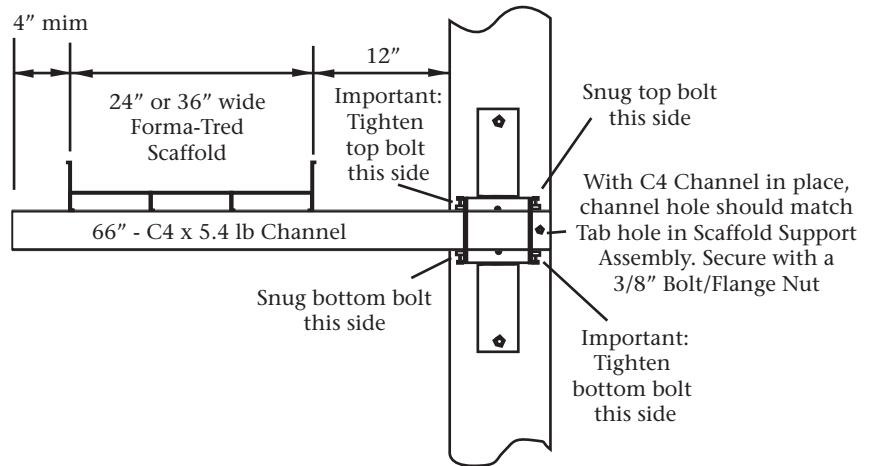

## Back-to-Back Scaffold for Wood Pole Structures

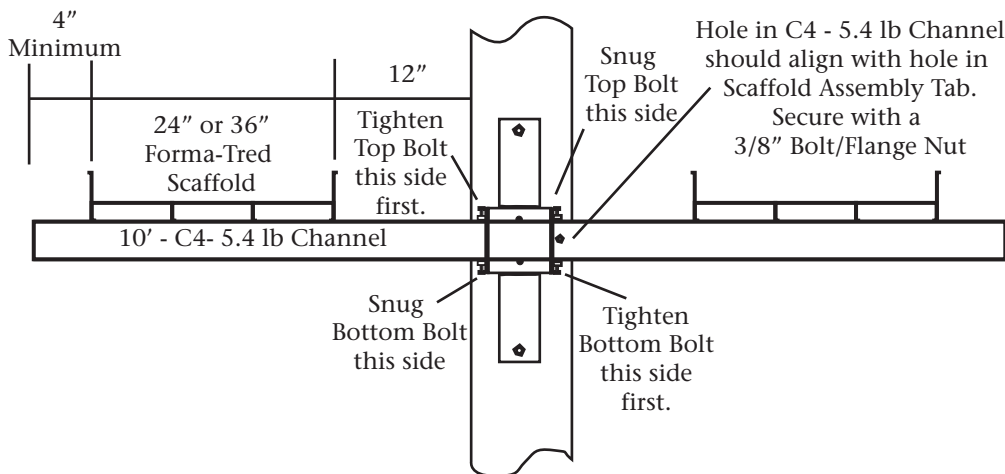

### Back-to-Back Scaffold Support Assembly Kit for Wood Pole Structure.

## Rear Scaffold Support Bracket Kit for Wood Pole Structures

### Rear Scaffold Support Assembly Kit for Wood Pole Structure.

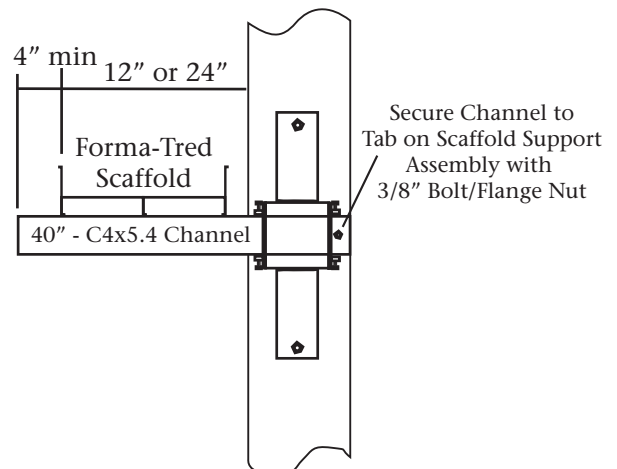

Excellence is our standard.

# Conduit Support Brackets

## Forma-Tred Conduit Support Brackets

Formetco Forma-Tred Conduit Support Brackets mount to the Forma-Tred Scaffold by hooking over the Kickrails and bolting into the scaffold leg for a secure support for the lighting conduit. The “U” Bolts and nuts work on 1 1/4” round or square conduit.

Locate the centerline of the lighting fixture conduit and mark on the top of both Kickrails. Place a Forma-Tred Conduit Support Bracket in place and drill a 5/16” hole through the Kickrail and scaffold leg.

Place a 5/16”x1 1/4” bolt through the hole in the center of the Conduit Support Bracket. Insert the Spacer over the bolt on the back side. Place Conduit Support Bracket over the top of the Kickrail with the end of the bolt through the drilled hole in the scaffold. Secure with a nut to the scaffold.

Install the “U” Bolt and attach the two nuts. Do not tighten. Place Conduit Support Brackets on the Kickrails on both sides of the scaffold. Insert the Formetco pre-wired conduit through the “U” Bolts. Position the end the proper distance from the face as required by the fixture manufacturer and tighten the “U” Bolts. Install the light fixtures.

Conduit Support Bracket  
Forma-Tred Scaffold

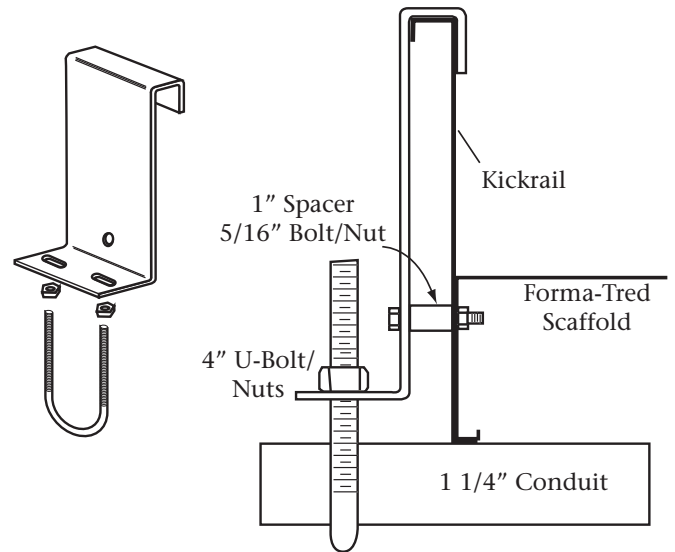

Conduit Support Bracket  
for 4' & 5" Angle Iron  
Kickrails

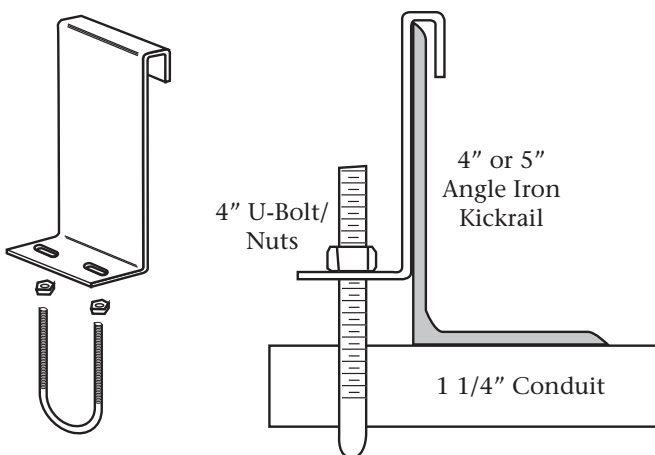

## Formetco Angle Iron Conduit Support Bracket

Formetco Angle Iron Support Bracket is designed for 3" or 4"/5" angle iron kickrails. Attach the “U” Bolt to the Conduit Support Bracket and place the Conduit Support Bracket on the angle iron kickrail. Slide the Formetco Pre-Wired Conduit (round or square), or your conduit, through the “U” Bolt.

Position the end of the conduit to the requirements for the fixture and tighten the nuts on the “U” Bolts. Attach the fixture and connect the wiring.

# Formetco QuickChange™ Conduit Support Brackets

The Formetco QuickChange™ Conduit designed for the AdVue Fixture. The Ad-Vue Pre-Wired Conduit comes in a Kit containing the hinged Conduit, a Heavy Duty Front Conduit Support Bracket and a Rear Conduit Support Bracket. The Ad-Vue Conduit Support Bracket Kit and be ordered for Formetco Forma-Tred Scaffold Kickrails or 3", 4"/5" angle iron kickrails.

Conduit Support Brackets  
Back Support  
available for  
3" Angle Iron Kickrails or  
4" Angle Iron Kickrails or  
6" Formetred Scaffold Kickrails

Conduit Support Assembly  
Front Support  
available for  
3" Angle Iron Kickrails or  
4" Angle Iron Kickrails or  
6" Formetred Scaffold Kickrails

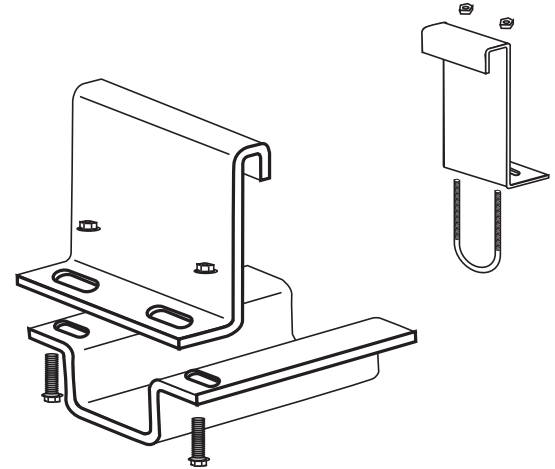

The Formetco QuickChange™ Conduit is hinged to allow you to easily change lamps or perform routine maintenance without using a bucket truck.

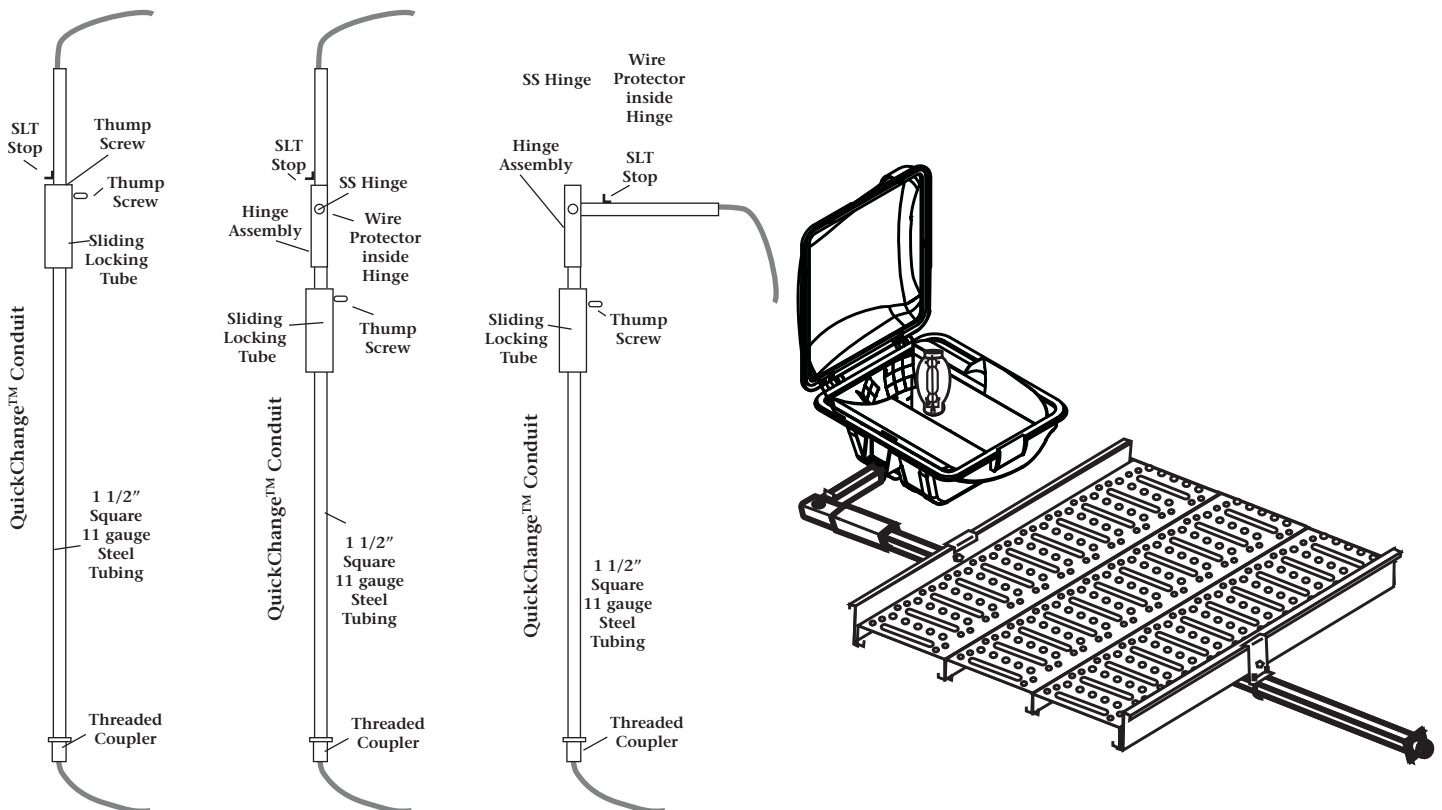

# Formetco Forma-Tred Scaffold Walkaround Assembly

## Assembly of the Walkaround

On a 14' x 48' Formetco Forma-Tred Scaffold Walkaround is made up with a 36" x 24' section and a 36" x 27' section length to accept the 36" Walkaround. The Kickrails are standard 24' length plus the Kickrail Extensions and is included in the Walkaround Kit.

Assemble the sets of 36" x 51' Formetco Forma-Tred Scaffold for each side of the structure. Attach a 144" Kickrail Extension on the outside of each set. Install End Caps inside the outside and inside scaffold section on the Walkaround end of each of the scaffold sets.

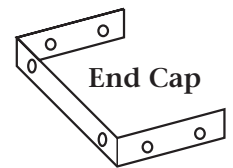
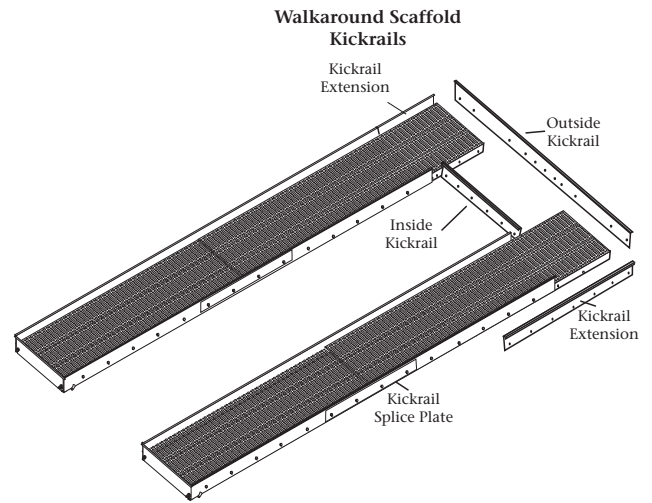
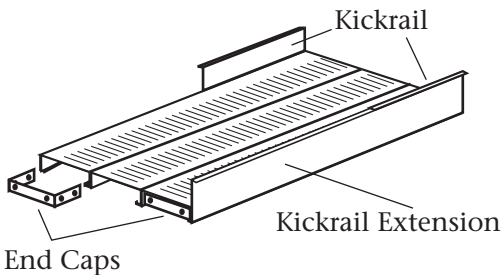

## Crossover Scaffold Section

To assemble the Crossover Section bolt the three sections of Scaffold together. Install end caps on both ends of all three legs. Set the assembled Crossover Set between the two sets of scaffolds and bolt to each side with six bolts/ flange nuts to the side of the 51' scaffolds.

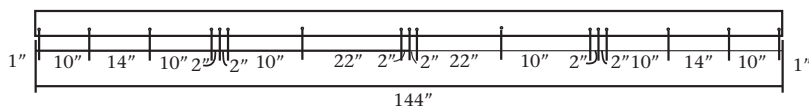
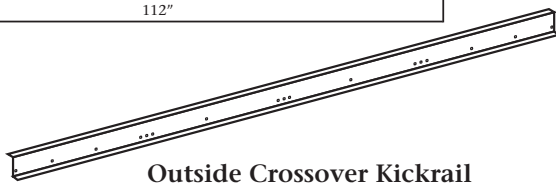
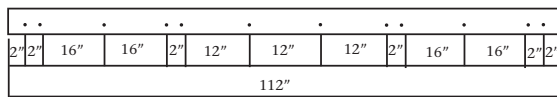
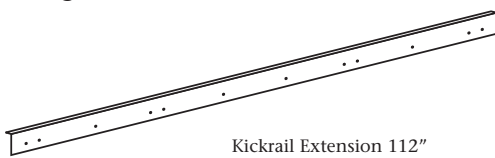
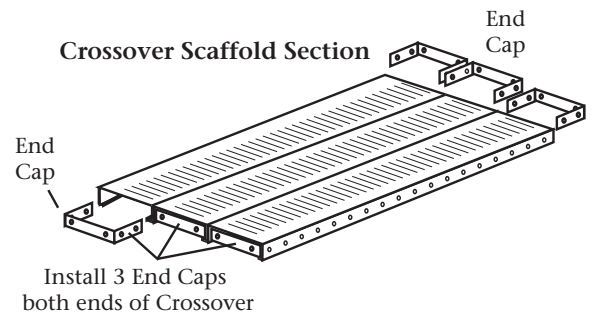

Attach the Outside Crossover Kickrail and the Inside Crossover Kickrail. Secure the top of the Kickrails where they overlap the side Kickrails with screws through the flanges. Your scaffold is now complete. Optional Handrails can be added for extra safety.

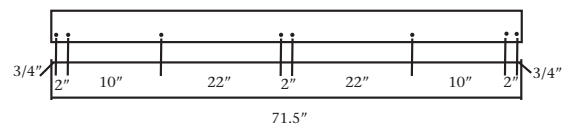
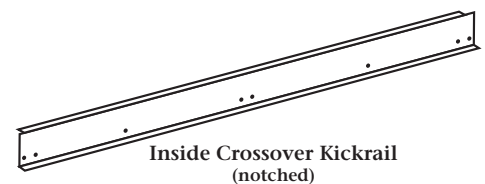

# Formetco Forma-Tred Scaffold Walkaround Handrail Assembly

## Walkaround Handrail Details

Locate the location of the Handrail Post. Mark the Kickrails where each Handrail Post will be located.

Attach the Left and Right First Handrail Post Support Angles to the underside of the Scaffold with 2" Hook Bolts/Flange Nuts with the extended side to the outside of the scaffold sets.

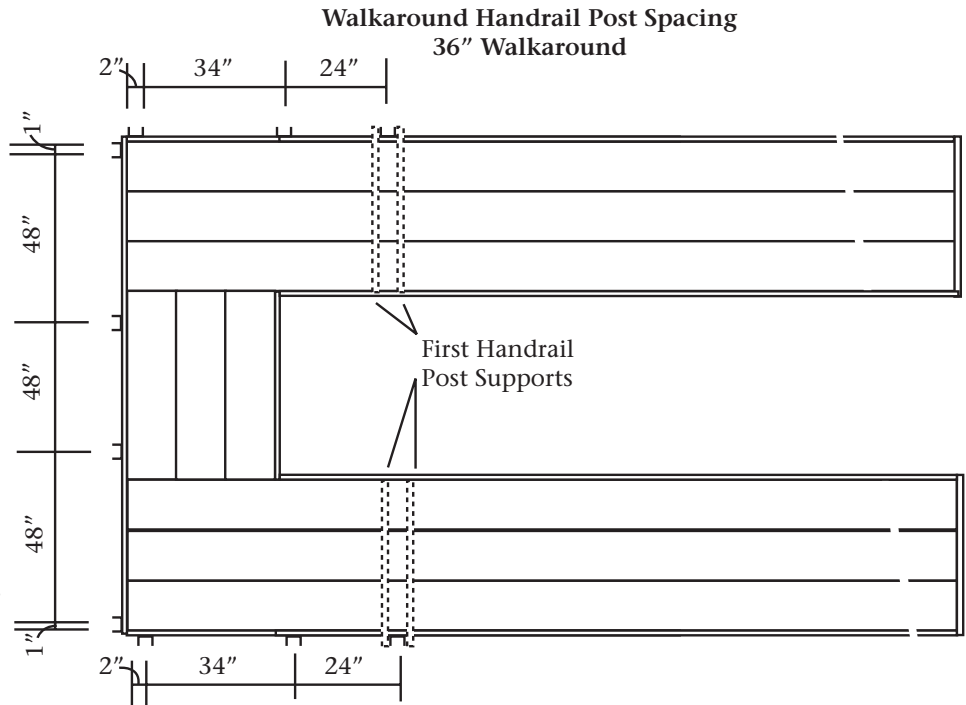

### First Handrail Post Support Angles Right & Left

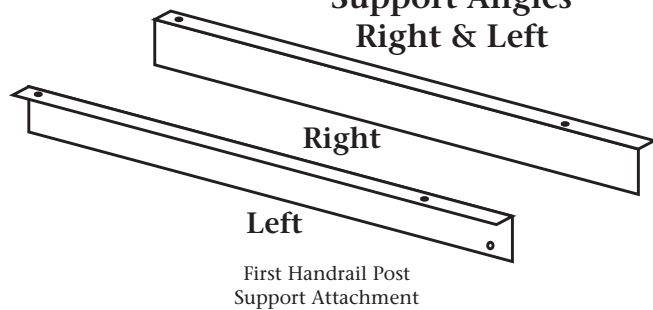

### First Handrail Post Support Angle

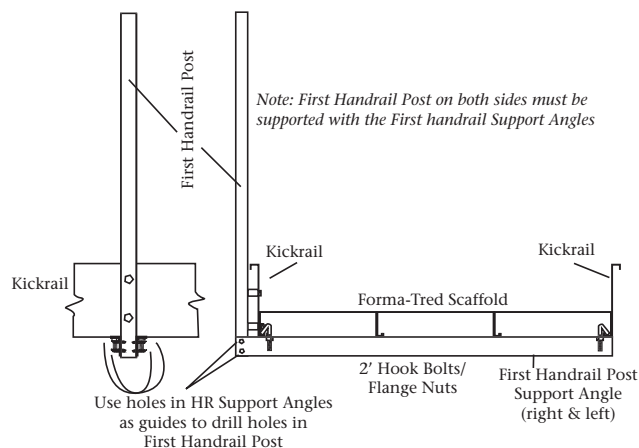

Fasten Handrail Post to scaffold with a bolt/nut and Spacer through the bottom hole with the Handrail Post between the Support Angles. Drill holes in the Handrail Posts at the bottom aligned with the holes in the Support Angles. Secure with bolts/nuts. Drill a hole through the scaffold aligned with the top hole in the Handrail Post. Secure to scaffold with a bolt/nut and Spacer.

# Formetco Forma-Tred Scaffold Walkaround Handrail Assembly

Typical Handrail Post Attachment  
48" High

With the First Handrails Posts on each side attached you can attach the rest of the Handrail Posts.

Secure the Handrail Post with a bolt/nut and Spacer at the bottom hole to the scaffold and Kickrail. Using the top hole as a guide, drill a hole through the Kickrail and scaffold and secure with a bolt/nut and Spacer.

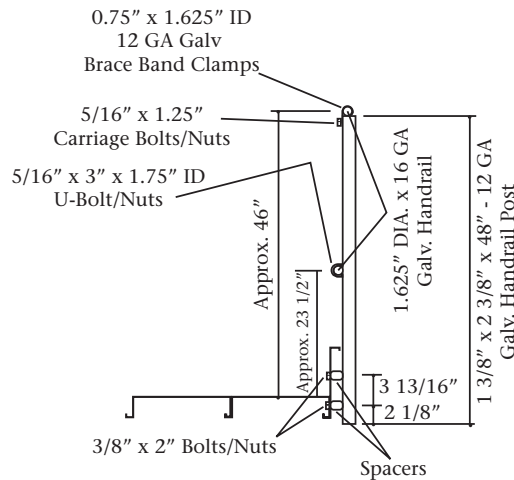
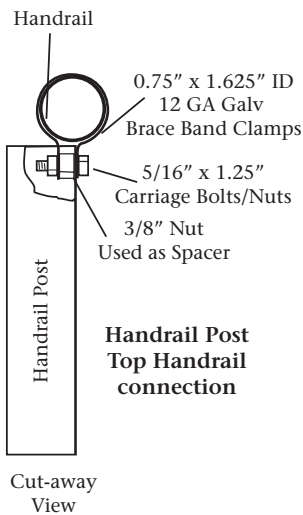
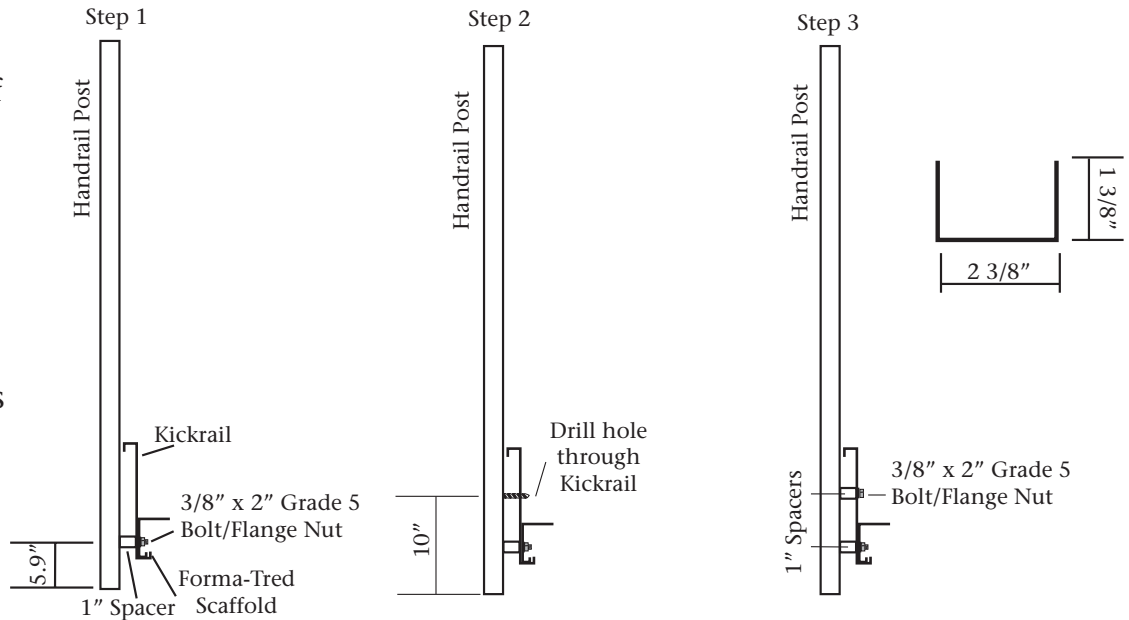

Typical Handrail Location

Cut the 16 gauge, 1.625 Diameter Galvanized Handrails to the lengths needed.

Attach the top Handrail to the Posts with the 12 gauge Brace Bands. Use a nut as a spacer in the Brace Band. Use a Handrail extender if railing is not long enough to reach length needed. Place Handrail End Caps in the ends of the Top Rails. Cut and install the middle Handrails with 3" "U" Bolts with nuts and lock washers.

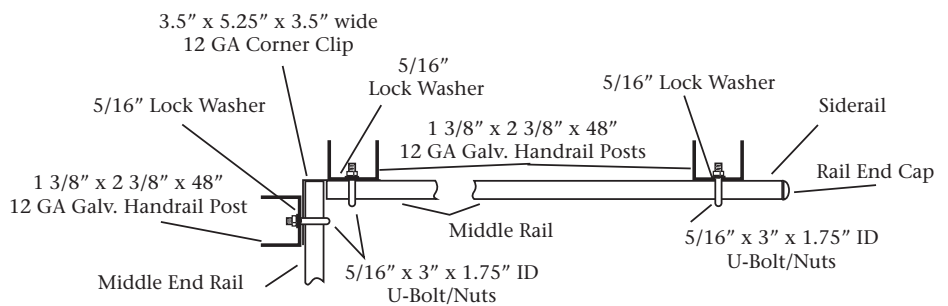

Middle Rail Corner Detail



# Forma-Tred Scaffold Typical Bolt Spacings

## \*SCAFFKR36X36 36" x 36' Forma-Tred Scaffold Bolt Spacing Guide

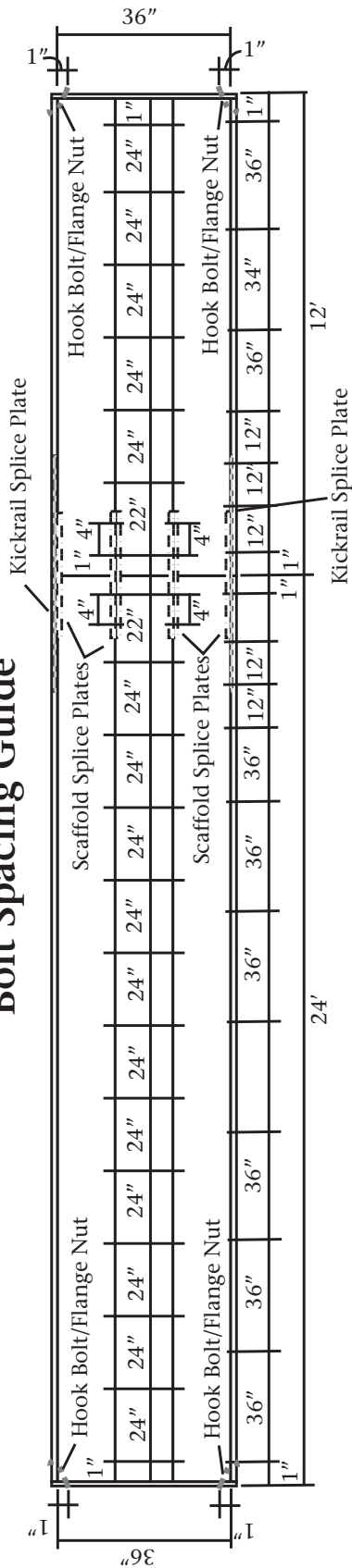

## \*SCAFFKR36X32 36" x 32' Forma-Tred Scaffold Kit Bolt Spacing Guide

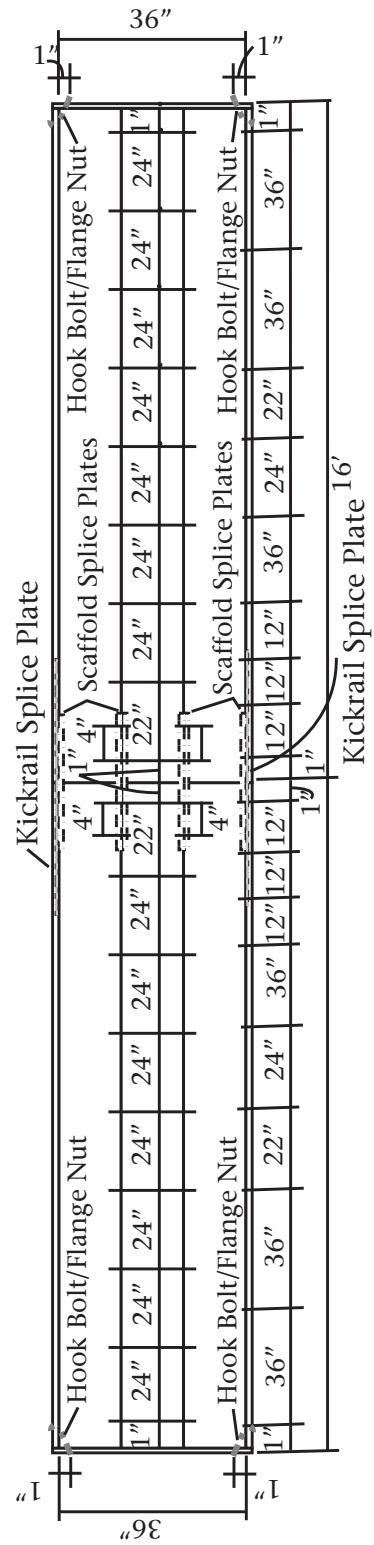

# Forma-Tred Scaffold Typical Bolt Spacings

**\*SCAFFKR36X24 Forma-Tred Scaffold Bolt Spacing**

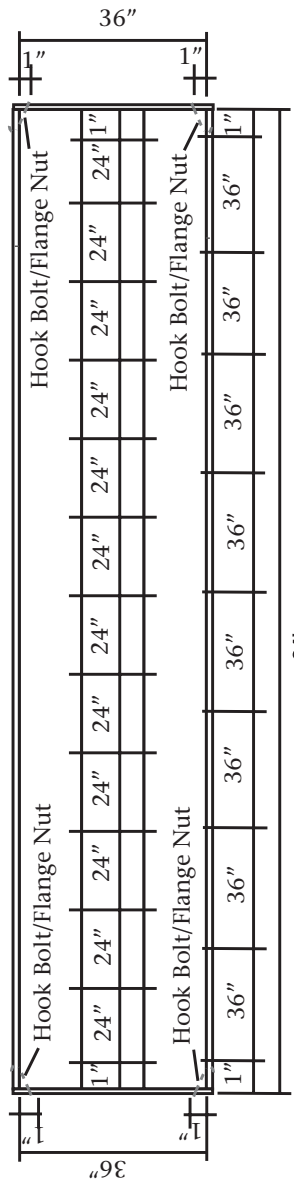

**\*SCAFFKR36X48 36" x 48' Forma-Tred Scaffold Bolt Spacing Guide**

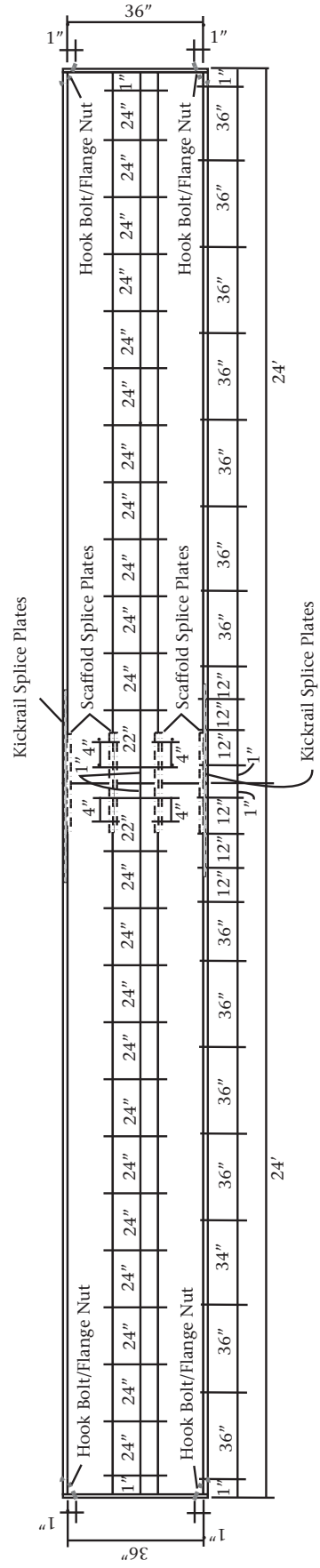

**\*SCAFFKR36X44 36" x 44' Forma-Tred Scaffold Bolt Spacing Guide**

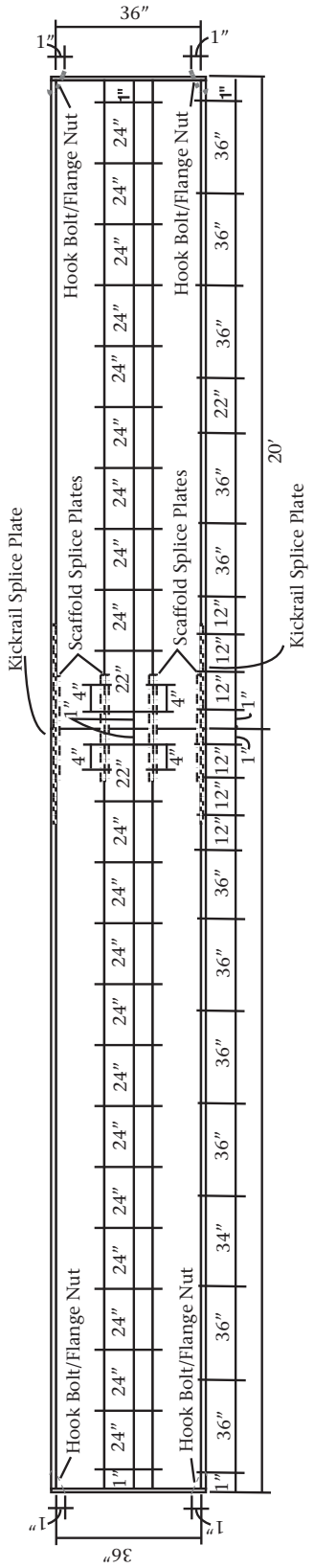

# Forma-Tred Scaffold Walkaround Typical Bolt Spacings

